

[TEATRO[®]]

ultra-thin speakers

PHASE[®]
TECHNOLOGY
SPEAKERS FOR YOUR LIFE

OWNER'S MANUAL & INSTALL GUIDE

TFS1.0 • TCE1.5

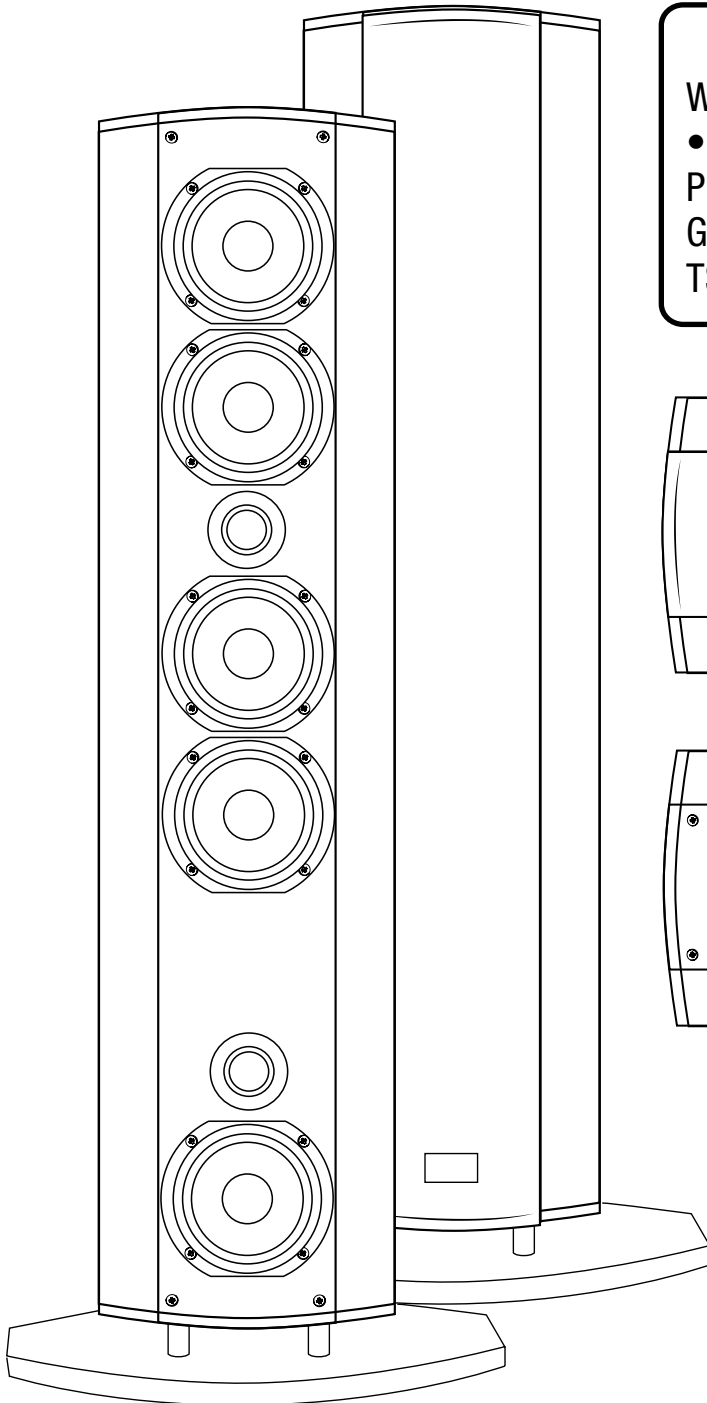

[TEATRO[®] TFS1.0 & TCE1.5 FEATURES]

WALL MOUNT OR TABLE TOP STAND OPTIONS

- BRUSHED BLACK ALUMINUM CABINET
- PRESSURE FIT POWDER-COATED ALUMINUM GRILLES
- 1.5" DEEP, MODELED AFTER THE TSB3.0 SOUNDBAR

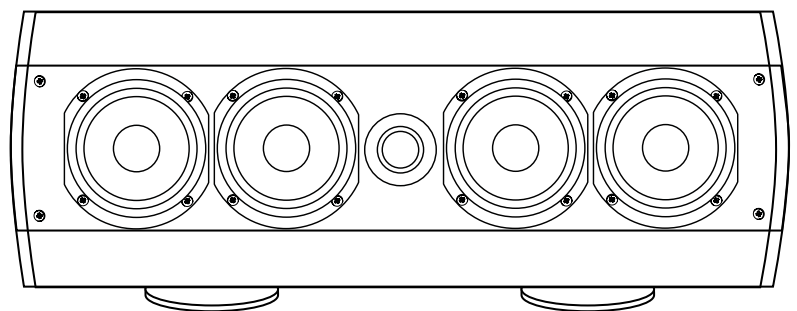
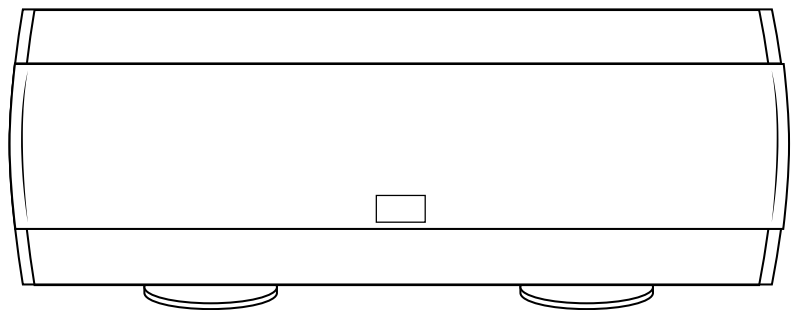

INCLUDED IN THE BOX	2
SAFETY INSTRUCTIONS	3
WALL MOUNTING INSTRUCTIONS	4
HOOK UP DIAGRAM FOR THE TCE1.5 SPEAKER	6
CARING FOR YOUR SPEAKERS	6
MAINTENANCE AND SERVICE	7
TROUBLESHOOTING	7
WARRANTY	7
SPECIFICATIONS	8

[INCLUDED IN THE BOX:]

1. TEATRO TFS1.0 OR TCE1.5

THE TCE1.5 IS SUPPLIED WITH A TABLE TOP PLEXIGLASS STAND; THIS STAND IS OPTIONAL FOR THE TFS1.0.

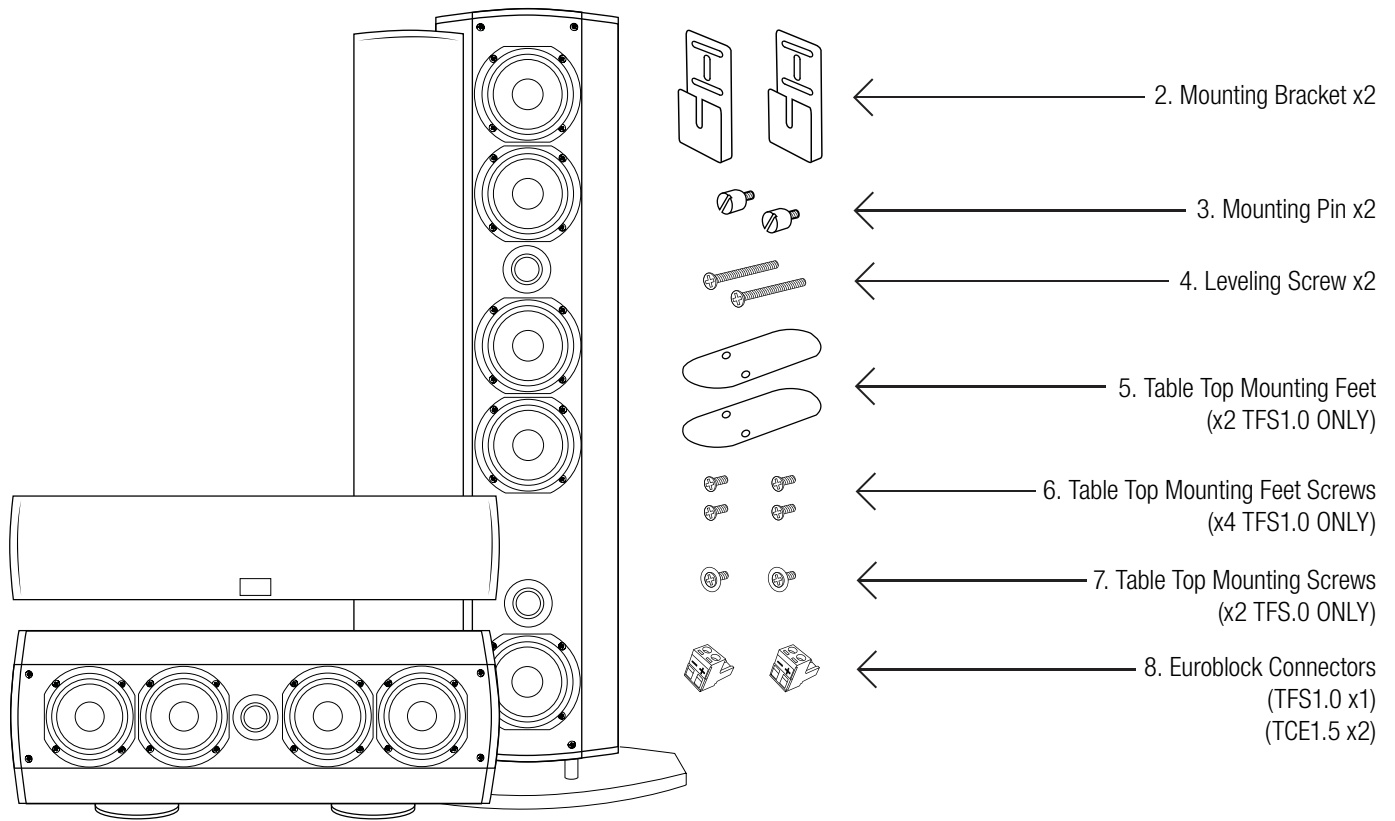

Thank you for purchasing the Phase Technology TEATRO® Ultra-Thin Speakers. These high-definition slim line speakers are the perfect complement to today's thin profile flat panel TVs. These speakers incorporate unique technologies to provide you with outstanding dialogue clarity along with wide open sound stage imaging for a great home theater experience.

The TEATRO® TSF1.0 or TCE1.5 speaker designs are made to fit seamlessly next to a flat panel TV. Both tabletop and wall mounting options are included with the product. For on-wall applications, the mounting brackets are adjustable for lining up and vertically leveling the speaker with the TV. The speaker cabinets also have threaded inserts for mounting the TEATRO® speakers to a display wall bracket mechanism.

The TEATRO® TCE1.5 speakers are designed to be the main front sound stage in a home theater system by providing 3 channels from 2 speaker systems. The center channel acoustic information is created by independent speaker elements located in each speaker enclosure. This eliminates the need for a center speaker that needs to be located either under or over the display monitor. The TCE1.5 is made from an extruded aluminum enclosure that provides several mounting options. There are threaded brass inserts in the rear of the cabinet for use with the included wall hanging bracket or smoked Plexiglas table top stand.

The Teatro TFS1.0 speaker system offers the same audio performance and utilizes the same extruded aluminum construction as the TCE1.5 speaker system. It is designed to complement the TCE1.5 LCR or the TSB3.0 Sound Bar speakers as rear channel surround speakers. In addition the TFS1.0 may be used as main separate front and surround speakers for a complete 5.1 to 7.2 surround home theater system. The TFS1.0 may either be hung on the wall with the provided brackets or placed horizontally on a shelf with the provided feet. The speaker can also use the optional TPB-1 Plexiglas display stand for vertical table top placement.

Regardless of application, serious audiophile listening or home theater, we recommend that you take the time to read this manual thoroughly before connecting speakers to your amplifier or receiver. In the highly unlikely event that you should experience a problem with set-up or operation, please contact one of our authorized dealers for assistance, or contact us directly.

Phase Technology Corporation
8005 W. 110th St., Suite 208
Overland Park, KS 66210
855.663.5600 (Domestic)
+1.913.663.5600 (International)
Fax: 913.663.3200

[SAFETY INSTRUCTIONS]

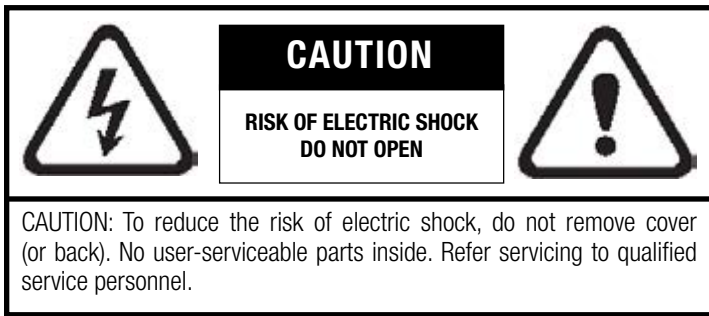

Explanation of Graphical Symbols



The lightning flash with arrowhead symbol, within an equilateral triangle, is intended to alert you to the presence of un-insulated "dangerous voltage: within the product's enclosure that may be of sufficient magnitude to constitute a risk of electric shock to persons.



The exclamation point within an equilateral triangle is intended to alert you to the presence of important operating and maintenance (servicing) instructions in the literature accompanying the appliance.

1. Read Instructions - All the safety and operating instructions should be read before the appliance is operated.

2. Retain Instructions - The safety and operating instructions should be retained for future reference.

3. Heed Warnings - All warnings on the appliance and in the operating instructions should be adhered to.

4. Follow Instructions - All operating and other instructions should be followed.

5. Water and Moisture - The appliance should not be used near water - for example, near a bathtub, washbowl, kitchen sink, laundry tub, in a wet basement, or near a swimming pool, etc.

6. Carts and Stands - The appliance should be used only with a cart or stand that is recommended by the manufacturer.

PORTABLE CART WARNING



7. Wall or Ceiling Mounting - The appliance should be mounted to a wall or ceiling only as recommended by the manufacturer.

8. Ventilation - The appliance should be situated so that its location or position does not interfere with its proper ventilation. For example, the appliance should not be situated on a bed, sofa, rug, or similar surface that may block the ventilation openings; or placed in a built-in installation, such as a bookcase or cabinet

that may impede the flow of air through the ventilation openings.

9. Heat - The appliance should be situated away from heat sources such as radiators, stoves, or other appliances that produce heat.

10. Power Source - The appliance should be connected to a power supply only of the type described in the operating instructions or as marked on the appliance.

11. Power Cord Protection - Power supply cords should be routed so that they are not likely to be walked on or pinched by items placed up or against them, paying particular attention to cords at plugs, convenience receptacles, and the point where they exit from the appliance.

12. Cleaning - The appliance should be cleaned only as recommended by the manufacturer.

13. Nonuse Periods - The power cord of the appliance should be unplugged from the outlet when left unused for a long period of time.

14. Object and Liquid Entry - Care should be taken so that neither objects fall nor liquids spill into the inside of the appliance.

15. Damage Requiring Service - The application should be serviced by qualified service personnel when:

- the power supply cord or the plug has been damaged,
- objects have fallen onto or liquid has been spilled into the appliance,
- the appliance has been exposed to rain,
- the appliance does not appear to operate normally or exhibits a marked change in performance, or
- the appliance has been dropped or the cabinet damaged.

16. Servicing - The user should not attempt to service the appliance beyond those means described in the operating instructions. All other servicing should be referred to qualified service personnel.

17. Grounding or Polarization - Precautions should be taken so that the grounding or polarization means of an appliance is not defeated.

APPLICABLE FOR USA, CANADA OR WHERE APPROVED FOR USAGE

CAUTION: TO PREVENT ELECTRIC SHOCK, MATCH WIDE BLADE PLUG TO WIDE SLOT, INSERT FULLY.

ATTENTION: POUR EVITER LES CHOCS ELECTRIQUES, INTRODUIRE LA LAME LA PLUS LARGE DE LA FICHE DANS LA BORNE CORRESPONDANTE DE LA PRESE ET POUSSER JUSQU'AU FOND.

[WALL MOUNTING INSTRUCTIONS]

It is prudent to take a few extra minutes to carefully inspect and measure the wall where you intend to mount the TFS1.0 or TCE1.5 speakers and your flat panel display. An inspection of the room, or rooms, that back up to the wall you have selected for mounting the speakers can often alert you to potential obstacles. An **electronic stud-finder** is a useful tool to assist you in selecting the speaker placement, but be cautious as they often give false readings. For example, if the wall you want to mount to happens to be the common wall for a bathroom or kitchen, there is a good chance you will encounter water or sewer pipes in the wall that will not be detected by a stud-finder. It is recommended, that wherever possible, you try to fasten these mounting brackets to a vertical stud with the appropriate wood screws. If it is not possible to mount the brackets over the studs then it is recommended that the appropriate hollow wall anchors or toggle bolts be used to mount the speakers.

STEP 1- FRONT CHANNELS

Determine that the desired mounting location is safe and clear of any physical obstructions that might hinder the proper installation of the speakers. If the flat panel monitor is already installed on the wall you can use it as a guide for the installation of the speaker. For the best appearance, it is recommended that the speakers be installed symmetrically next to the monitor. The TEATRO's response characteristics will be best if you mount it within a few inches of the flat panel display.

NOTE: Special consideration must be taken to run two (2) sets of speaker leads for each of the TCE1.5 speakers. One pair each will be connected to the Front left and right channel output on your amplifier and the other two pair will be used for the Center channel and be connected together in parallel at the amplifier. Be certain that you can get the speaker wire to the locations where you plan to mount the speaker systems.

Please note that the TEATRO® speakers are designed to mount very close to the wall and the brackets only allow about .5" of clearance so be certain to make allowances for this with your speaker connectors and wire clearances.

We suggest that you use a minimum of AWG 16 stranded wire. Pre-run your speaker wire to the determined locations and be certain to leave about two feet of extra wire for the final speaker installation. If the flat panel monitor is not yet mounted to the wall, mount the display first before mounting the speakers.

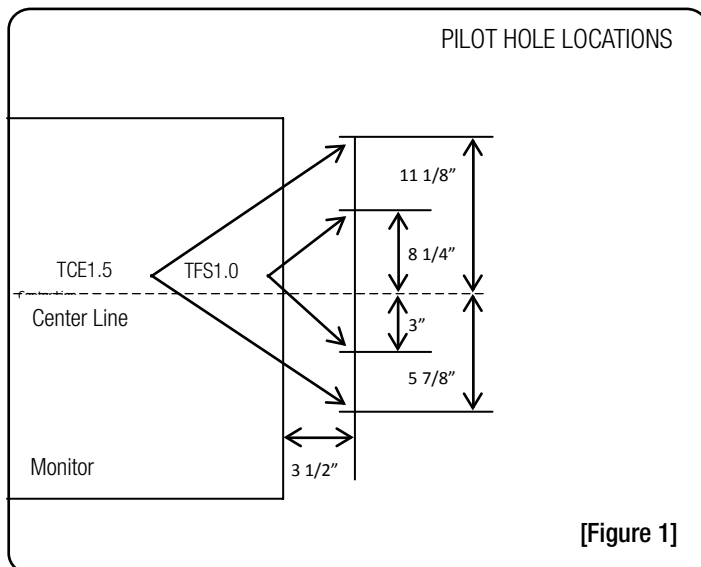

STEP 2A- VERTICAL WALL MOUNTING HANGER BRACKETS

For the best audio experience, the TEATRO speaker should be centrally aligned and mounted directly next to the TV display. Each speaker comes with two identical Mounting Brackets and these should be mounted to the wall centrally located next to the TV monitor (Figure 1).

First locate the horizontal center line of your TV display and make a light pencil mark on the wall that is 3 1/2" from the side edge of your display. Next, measure above and below this mark and make another mark at these points per the diagram for the TEATRO® speaker you are installing. (Figure 1). Repeat this process on the other side of the display – making sure that these marks are level with the marks on the opposite side. This will create four (4) marks that are locations for the hanging brackets.

Using a 1/16" drill bit, drill a pilot hole at each of your two marks above. Place one of the wall brackets on the wall and align the pilot hole with the bottom slot on the bracket and drill a second pilot hole in the center of the upper slot on the bracket. (Figure 4). This hole will be 7/8" above the first pilot hole. Repeat this process for the bracket on the other side. These pilot holes will let you know if your mounting bracket location is over a wall stud or not. If it is over a stud then that bracket can be installed with a suitable screw (for mounting on sheetrock walls, we recommend at least a #10 x 1.5" pan head screw and a flat washer between the screw and the bracket). If the location for the bracket is not over a wall stud, then suitable drywall anchors that can support 15 lbs. each must be used.

Once they are installed check that the center distance between the vertical mounting slots on the two sets of brackets is exactly 11 1/4" for the TFS1.0 or 17" for the TCE1.5. Adjust the brackets with the vertical slots until the correct distance apart.

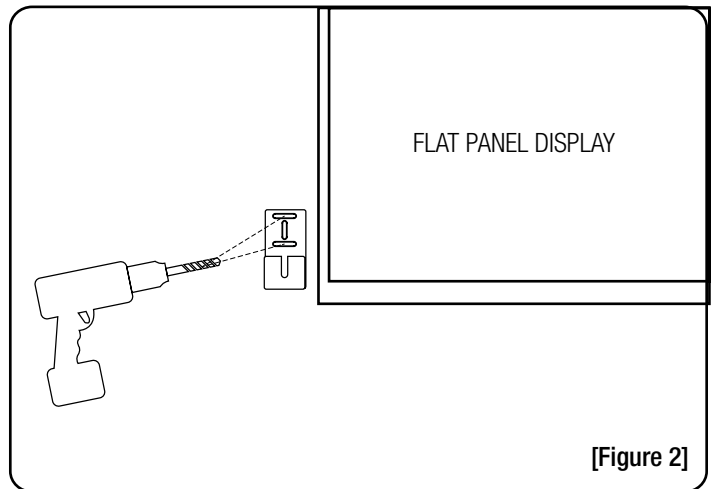

STEP 2-B – HORIZONTAL WALL MOUNTING

The Teatro speakers may also be installed horizontally to a wall. The process for a horizontal installation is similar to the vertical installation except for the mounting measurements. If you are locating the speakers below a TV first locate the center line of your TV display and make a light pencil mark on the wall that is 2" below the bottom of your display.

BRACKET MOUNTING DISTANCE CENTER TO CENTER

TFS1.0 11 1/4" C-C, 5 5/8" FROM CENTER
 TCE1.5 17" C-C, 8 1/2" FROM CENTER

Next, measure to the left of this mark to the bracket center distance as noted in the reference table and make another mark at that point. Make sure this mark is also 2" below the TV. Repeat this process on the right side

of the display – making sure that this mark is level with the mark on the left side. This will create two marks that are the correct mounting distance apart and 2" below the bottom of your display (Figure 3). You have now identified the location for the two wall brackets for the TEATRO® speaker.

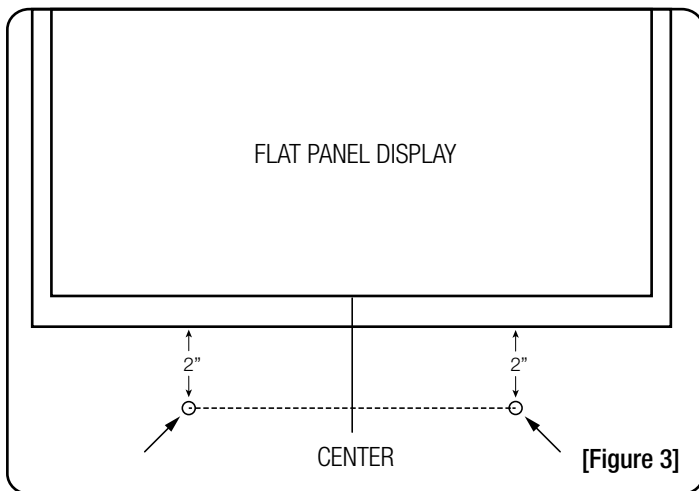

[Figure 3]

Using a 1/16" drill bit, drill a pilot hole at each of your two marks above. Place one of the wall brackets on the wall and align the pilot hole with the bottom slot on the bracket and drill a second pilot hole in the center of the upper slot on the bracket (See Figure 4). This hole will be 7/8" above the first pilot hole. Repeat this process for the bracket on the other side. These pilot holes will let you know if your mounting bracket location is over a wall stud or not. If it is over a stud then that bracket can be installed with a suitable screw (for mounting on sheetrock walls, we recommend at least a #10 x 1.5" pan head screw and a flat washer between the screw and the bracket). If the location for the bracket is not over a wall stud, then suitable drywall anchors that can support 15 lbs. each must be used.

Following the guidelines above, mount the two brackets to the wall. Once they are installed check that the center distance between the vertical mounting slots on the two brackets is exactly as specified in the reference table. Adjust the brackets with the horizontal slots until on they are the specified distance apart.

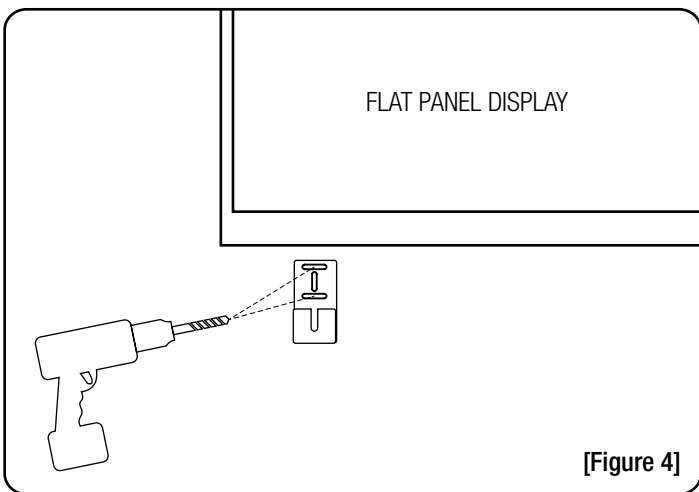

[Figure 4]

STEP 2-C – TABLE TOP MOUNTING

The TCE1.5 speaker is supplied with a Plexiglas table top stand for vertical placement; please refer to the instructions included with the stand for assembly. This stand is optional for the TFS1.0 speaker.

TFS1.0 TABLE TOP FOOT ASSEMBLY

Place your TFS1.0 speaker face down on a soft clean surface. Orient the speaker so the input terminal is on the right hand side. Attach the Table Top Mounting Feet to the bottom of the bracket using the two supplied Phillips Table Top Mounting Feet Screws. Make sure that you orient the feet so that the longer side extends under the TFS1.0 (Figure 5). Repeat this for the other Mounting Bracket and Table Top Mounting Foot. Once you have the Table Top Mounting Feet securely fastened to the Mounting Brackets, it is now time to mount them to the TFS1.0. Align the center of the vertical slot on the Mounting Bracket with the center of threaded brass inserts on the rear of the speaker and fasten using the supplied Table Top Mounting Screws, one for each bracket. (Figure 5).

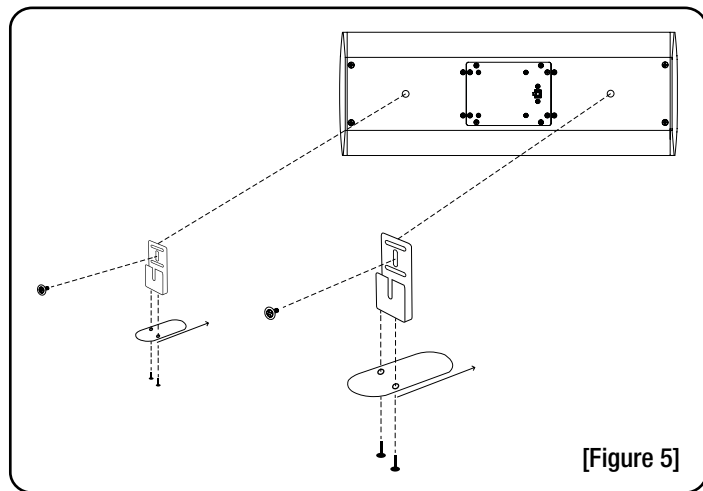

[Figure 5]

STEP 3 – SPEAKER HOOKUP

There are Euroblock connector terminals on the rear of the speaker cabinets. The terminals are marked for Front Input or Center Input on the TCE1.5 speaker or just Input on the TFS1.0 and should be connected to the respective speaker channel outputs on your receiver (Figure 8). Be careful to observe proper polarity; + (red) on your receiver to + on the speaker Euroblock connector. Strip about .25" of insulation from the wires and separate the wires as necessary. Using a small flat blade screwdriver, connect the signal wires to the 2-pin Euro-block connectors, (+) indicates positive and (-) indicates negative. Please reference your receiver owner's manual for proper speaker connection. Make sure the connections are tight. Tuck the speaker wires behind the speaker cabinets, using tie wraps if necessary. (Figure 6).

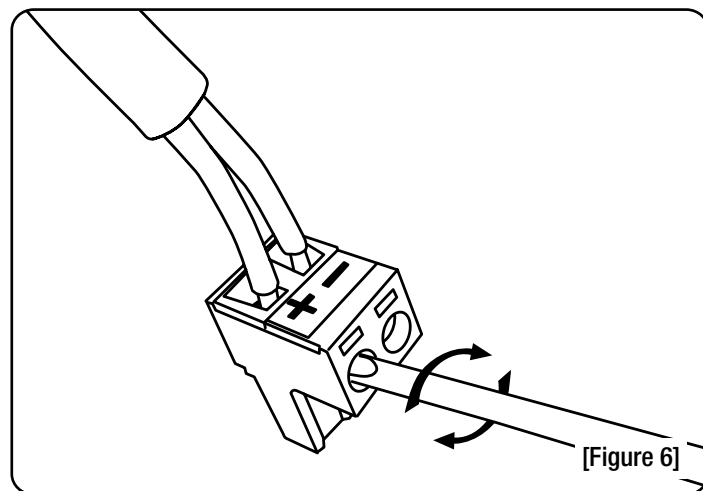

[Figure 6]

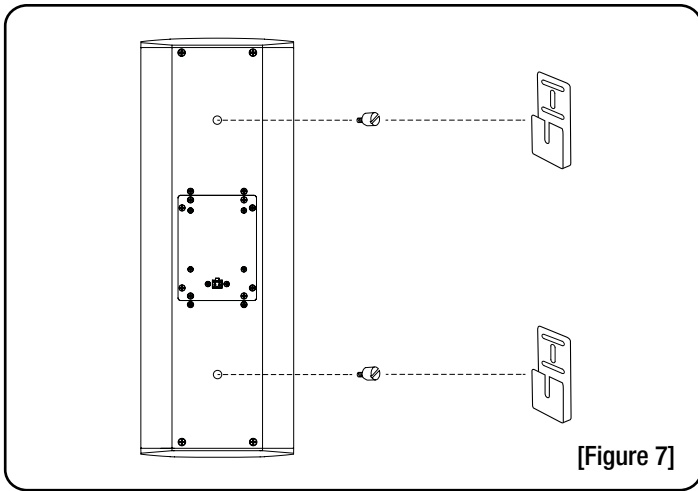

STEP 4 – FINAL WALL MOUNTING PROCEDURE

Locate the two holes on the back of the speaker that have the threaded brass inserts and install the two brass Mounting Pins in these holes (Figure 7). Your TEATRO® speakers are now ready to be mounted to the wall.

Gently slide the Mounting Pins into the vertical mounting slots on the Mounting Brackets. If necessary, the Leveling Screws may be inserted in the bottom of the Mounting Bracket and used to adjust the height. Tightening the screw will raise the speaker and loosening it will lower it.

NOTE: The PHASE TECHNOLOGY grille logo is a separate item with the TFS1.0 speaker and may be placed on the speaker grille in the appropriate position depending on whether the speaker is installed vertical or horizontal. Simply peel the backing off of the logo and place on the grille in the desired location.

STEP 5

Since the TCE1.5 speaker performs as the front three speakers in a home theater system they are to be used and set up as you would any normal 5.1 to 7.2 surround sound system for balance and level adjustments. For the best performance, the amplifier should be set to the small speaker mode for the left/center/right front speakers. The subwoofer setting should be set between 80 - 100 Hz. We recommended the use of our Phase Technology subwoofers and the TFS1.0 as the surround speakers to complement the sound and performance of the TCE1.5 or the TSB3.0 sound bar speakers.

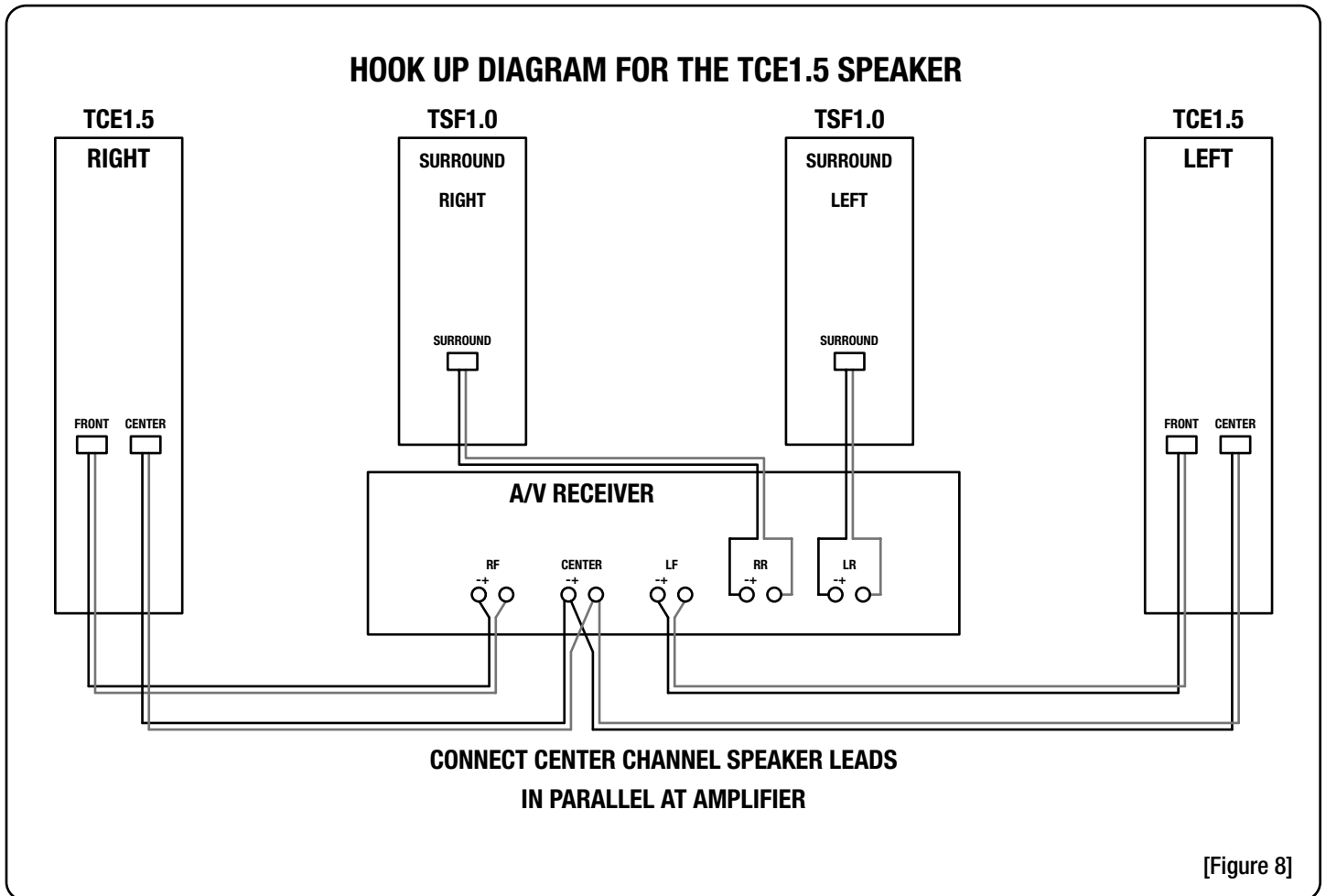

[Figure 8]

[CARING FOR YOUR PHASE TECHNOLOGY SPEAKER]

All Phase Technology speakers are finished with a high degree of craftsmanship in either hand polished paint or vinyl laminates. We recommend using a lint-free rag with a small amount of glass cleaner to maintain the long-lasting beauty of the finish. Avoid products containing silicones, oils, oil derivatives, or solvents. Enclosures finished in vinyl laminates may be cleaned with a damp cloth as necessary.

[MAINTENANCE AND SERVICE]

Because of Phase Technology's uncompromising quality control programs, it's unlikely that your speakers will ever need service if connected and used as outlined in this Owners' Manual. In the unlikely event that a problem does occur, please contact your Phase Technology dealer. Your dealer has the necessary factory-authorized parts and trained technicians to quickly restore your speaker to its original performance specifications.

[TROUBLESHOOTING]

NO SOUND

1. Verify that all components are plugged in and turned on.
2. Check all speaker wires and cables for loose connections.
3. Check to see if you have selected the proper source on your amplifier.

VOICES DO NOT APPEAR TO COME FROM BETWEEN THE SPEAKERS / BASS RESPONSE IS WEAK

1. Verify that all speaker connections from the amplifier to the speakers are running PLUS+ to PLUS+ and MINUS- to MINUS-.
2. Check to see if there are any furnishings or plants that may be blocking the output of a speaker.
Make sure nothing is directly in front of that speaker.

SOUND, BUT NO BASS (MOST LIKELY IN SYSTEMS WITH A SUBWOOFER)

1. Verify that the subwoofer is plugged into an AC outlet and power is turned on.
2. Check that the speaker wire / cable going from the amplifier/receiver to the subwoofer is securely fastened.
3. Check the volume control of the subwoofer.
4. Refer to your amplifier/receiver manual to make sure you have adjusted its bass output properly.

MUDDY OR BOOMY BASS

1. Check the volume control for the subwoofer. Excess volume can cause speakers to sound distorted and unnatural.
2. Try adjusting the crossover control on the subwoofer or the subwoofer setup on your receiver to a slightly lower frequency (example: reduce from 120 Hz to 80 or 60 Hz).
3. If the subwoofer or full size speaker is close to a corner, side or back wall, try moving it away from the wall. This may reduce the "boomy" bass considerably.
4. Bookshelf speakers placed in a semi-enclosed space or cabinet can artificially emphasize bass output. Reduce the bass control on your amplifier or move the speakers to the front of the cabinet. Alternatively, reposition the speakers to a more open location.

DISTORTED SOUND FROM THE SPEAKERS

1. This problem is usually caused by setting the volume control too high. Reduce the amplifier/receiver volume to a lower level.
2. If noise and distortion are audible at higher volume levels, your amplifier may not be powerful enough. Consider upgrading to a unit with higher power.

NOTE: Remember, even though your Phase Technology speakers can handle considerable power levels, ANY speaker if used improperly can be damaged. Consult your Phase Technology dealer for assistance in choosing a new amplifier or receiver.

[WARRANTY]

LIMITED WARRANTY: Phase Technology warrants its loudspeakers to be free from defects in material and workmanship for a period of ten (10) years for speaker product, limited lifetime for CI speakers, and three (3) years for the electronic components to the original purchaser. Purchase must be made from an authorized Phase Technology dealer.

This warranty does not cover service or parts to repair damage caused by misuse, abuse, damage while in transit, alterations, unauthorized repairs, failure to follow instructions, fire, flood or any other cause beyond the reasonable control of Phase Technology. Defects in speaker cabinets or grilles must be brought to the attention of your dealer immediately after purchase. This warranty will be void if the products' serial number has been altered or removed.

Should your Phase Technology product require service, please call the MSE Audio customer service department for a return authorization. All merchandise returned to Phase Technology without prior authorization will be refused. For your return authorization number, please call 855.663.5600 or email sales@mseaudio.com.

[SPECIFICATIONS]	TEATRO® TFS1.0	TEATRO® TCE1.5
TWEETER	.75" Soft Dome	(2) .75" Soft Dome
WOOFER	(2) 3" Polypropylene w/ NBR Surround	(3) 3" Polypropylene w/ NBR Surround
PASSIVE RADIATOR	(2) 3" Polypropylene w/ NBR Surround	(2) 3" Polypropylene w/ NBR Surround
FREQ RESPONSE	65 Hz - 20 kHz	65 Hz - 20 kHz
SENSITIVITY	90 dB	90 dB
IMPEDANCE	8Ω	8Ω
MAX POWER	100 W	100 W
DIMENSIONS	6.75" H x 18.5" W x 1.5" D	6.75" H x 26.5" W x 1.5" D
WEIGHT	5.8 lbs.	8.35 lbs.
FINISH OPTIONS	Black Brushed Aluminum	Black Brushed Aluminum
GRILLE	Black Powder-Coated Pressure-Fit Aluminum	Black Powder-Coated Pressure-Fit Aluminum
IMAGES		

Copyright © 2014 MS Electronics, LLC. All rights reserved. MSE Audio, Phase Technology and PhaseTech are registered trademarks and "Speakers for your Life" is a trademark of MSE Audio, Overland Park, Kansas USA. Phase Technology is part of MSE Audio®. www.phasetech.com.